

WHICH IS BETTER: THREE OR FOUR LOAD POINTS?

The answer is dependent upon several factors, including vessel shape and weight.

By Ted Kopczynski, Hardy Instruments



Install with care: Pictured is a compression load point installation on a four-legged vessel. Four legs offer a larger area to support the vessel, provide for equal load sharing among the legs, and help to keep the vessel from tipping over.

➤ It is a commonly asked question: Is it better to use three or four load points on a scale?

In theory, you can use any number of load points (load cells) to support a vessel. The actual number used is dependent upon these factors:

- The vessel's geometry (shape and number of supports).
- The vessel's gross weight (both live and dead weight).
- The vessel's structural strength.
- The environment in which the vessel is located.

- What is available structurally to provide a stable, load-bearing support.
- The characteristics of the material being weighed.

Three Load Points

For short, upright cylindrical vessels in a compression installation, three load points spaced at 120° intervals provide the most convenient support. Three-leg weighing systems balance like a tripod, with load distribution being virtually automatic, and they only require mi-

nor balancing at installation. You must install all of the load cells in the same plane within 3° of each other.

Cylindrical vessels suspended symmetrically in tension with three load points provide the advantage of equally distributing the load among the load cells. What is available structurally is important in this situation.

A vessel in tension can be hung in a corner where there are two supporting structures at right angles. All it requires is a 45° cross brace to provide support for the third load point. Of course, the support beams must be sufficiently strong and stiff to support not only the fully loaded vessel, but also other vessels that may be supported from the same structure, and any changes in the structural load, such as an accumulation of snow, water or ice.

Four Load Points

Square, rectangular, horizontal cylindrical, tall cylindrical vessels or those that require greater stability should use at least four load points: one in each corner. Vessels subject to fluid sloshing, material agitation or mixing, violent internal chemical reactions, high winds or seismic effects require greater stability to guard against tipping.

A four-leg weighing system adds structural strength but requires more care in the installation process to balance the loading on the four legs. With this type of support system, it is necessary to equalize, or level the base, to spread the load evenly among the four cells.

For scales with accuracy requirements equal to or greater than 0.1%, the base plate support surfaces must be within 0.4° (0.08mm/100mm). If one cell is mounted on a lightweight crossbeam that has a high deflection, it can sag and throw the load onto the two adjoining cells, possibly overloading them.

It is a simple but critical process to shim the load cells or, if equipped, fine-tune the adjusting bolts on the cell mounting hardware during installation to balance the four legs. Proper load sharing should have a difference of only $\pm 0.5\text{mV}$ between load points.

To accomplish this, measure the DC mV signal between each of the load sensors, plus and minus signal wires

The precision can be equal on one, three, four or more compression or tension load point systems.

with handheld meters, or through the weighing instrumentation if that feature is available.

Larger differences between load cells due to motors hanging off one side of the vessel or excessive or low flexing piping should not exceed $\pm 2.0\text{ mV}$ between the highest and lowest reading. Four legs also offer a larger area to support the vessel, provide for equal load

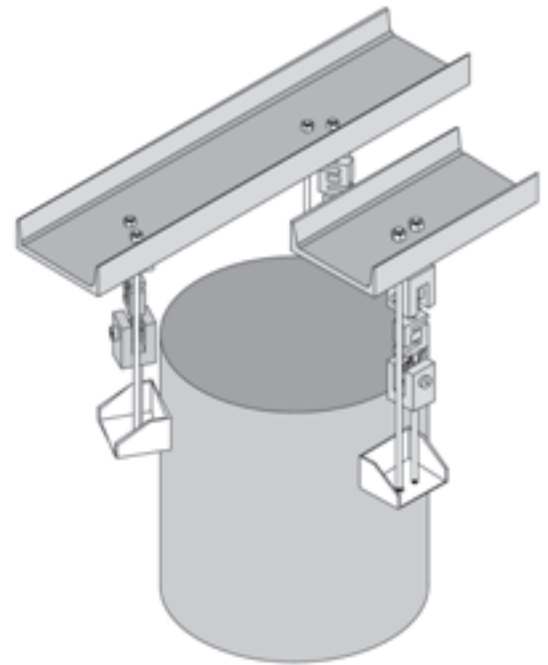
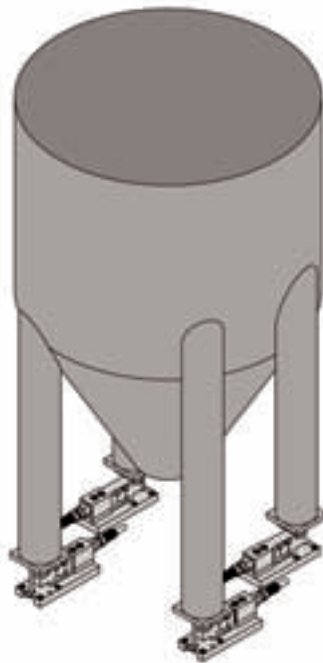

(Left to right) These illustrations show a vessel with compression load cells and another with tension load cells.

sharing among the legs, and help to keep the vessel from tipping over.

Long horizontal tanks with saddles symmetrically positioned in from the ends should also use four load points. If the material is self-leveling, and low accuracies of 0.5% or greater are acceptable, then using one or two load points at one end and flexures at the other is satisfactory. The load fraction seen by the load points must stay the same, no matter what the level in the vessel.

Very large capacity or heavy vessels in excess of 1 million pounds require more than four load points. Because the wall thickness and supporting structure of the vessel increase as the number of supports decreases, the vessel's dead weight and, therefore, installation costs, increase dramatically. These vessels usually are designed for six or eight load points.

Generally, you should not use any more than eight load points. It becomes proportionally more difficult

to get even weight distribution, and therefore better accuracy, on vessels with more than four load points.

Which System to Choose?

As for which system is better, there is no correct answer. The precision can be equal on one, three, four or more compression or tension load point systems. The road to higher accuracy is mostly in the care taken during system design and installation.

Taking into account level footings, balanced load points, absence of binding, flexible piping, environmental characteristics such as wind and temperature, and the load's center of gravity within the footprint of the scale all make for a good scale installation. □

Rockwell Automation Encompass™ Partner Hardy Instruments, San Diego, manufactures weight controllers and PLC weigh modules.

Hardy Instruments

www.rockwellautomation.com/go/p-hardy